

# Art Applewhite Rockets

from deep in the heart of Texas



## 24 mm Helix

Recommended motors: D11-P, D12-0, D12-3, E9-P, E9-4, Apogee E6-P & E6-4

Parts:

Wing – 1/8" x 1.63" Basswood sheet

Main Tube – LOC 38mm Tubing

Motor Mount – BT-50

Balance Beam – 3/8" Dowel

1/4" Launch Lug

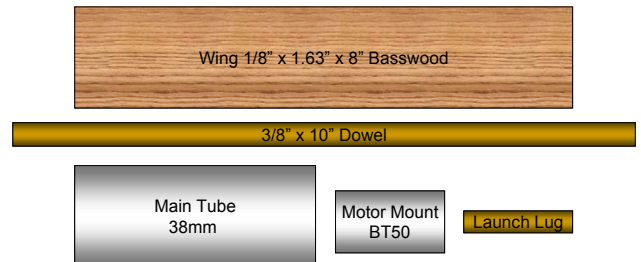

Additional Materials and Tools:

Elmer's Glue-All, #11 X-Acto® knife.

Construction Tips:

- Read **all** the instructions before starting construction.
- Test fit all parts before gluing them.
- **Elmer's Glue-All** is the only recommended glue for this kit.
- Allow the glue to dry before going to the next step.
- If you have any questions please contact Art Applewhite at [rocket877@aol.com](mailto:rocket877@aol.com)

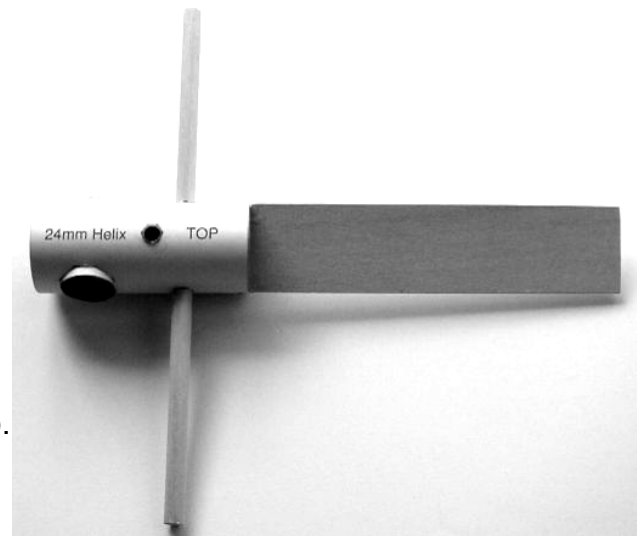

Construction:

1. On the Main Tube, cut out the Motor Mount (M), Launch Lug (L) and Balance Beam (B) holes using a #11 X-Acto® knife with a **NEW** blade. Cut directly on the printed lines and work slowly and carefully. The holes are shaped like hexagons and octagons (Polygons) to make cutting and assembly easier. The best way to cut out the holes is hold a #11 X-Acto® knife with a **NEW** blade perpendicular to the Main Tube and push the tip into the side of the tube. Push the point slowly in until it cuts the width of one side of a polygon. Then go to the next side of the polygon and repeat until all the sides are cut out. Repeat until all six of the holes are cut out.

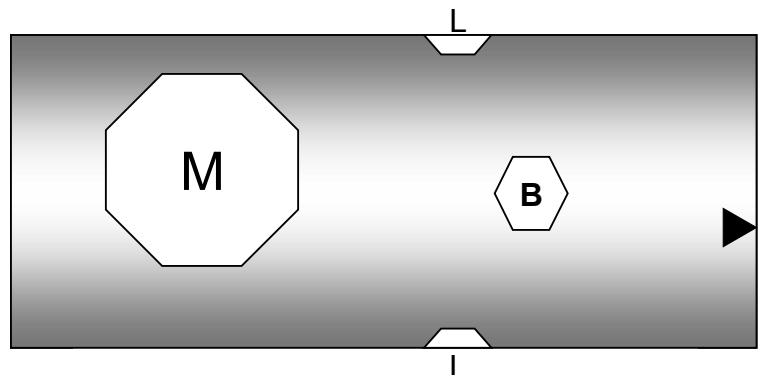

## 24 mm Helix - Page 2

2. Test fit all the parts in their respective holes. Carefully enlarge the holes as needed for a snug fit.
3. Insert and center the Balance Beam in the 0.38" holes (B).
4. Insert and center the Launch Lug in the 0.35" holes (L).
5. Insert and center the Motor Mount Tube in the 1" holes (M). Note: It is easier to insert the Motor Mount if you put a spent 24mm motor in it first. Apply a fillet of glue on the inside where the Motor Mount Tube and the Main Tube meet.
6. Apply fillets of glue on the outside at each place where the Balance Beam, Launch Lug and Motor Mount meet the Main Tube.
7. Trim about 1/16" from the leading and trailing edges of the Wing up to just over 1 inch from the root edge. Check that the Wing fits snugly into the end of the Main Tube. Trim a little at a time and don't take off too much.
8. The Wing should rest against the Balance Beam. The Main Tube should warp slightly out of round and the Wing should fit snugly. Note: Make sure the leading and trailing edges of the Wing are centered on the points of the small triangles at the end of the Main Tube. Before the glue sets, make sure the Wing is sticking straight out from the Main Tube as viewed from both the top, side and end.
9. Run fillets of glue on the inside of the Main Tube at all places where it and the Wing meet. Allow the glue to dry completely before painting.
10. Apply a light coat of paint to protect the rocket from moisture. Do not use too much paint as this will add too much extra weight and upset the balance.

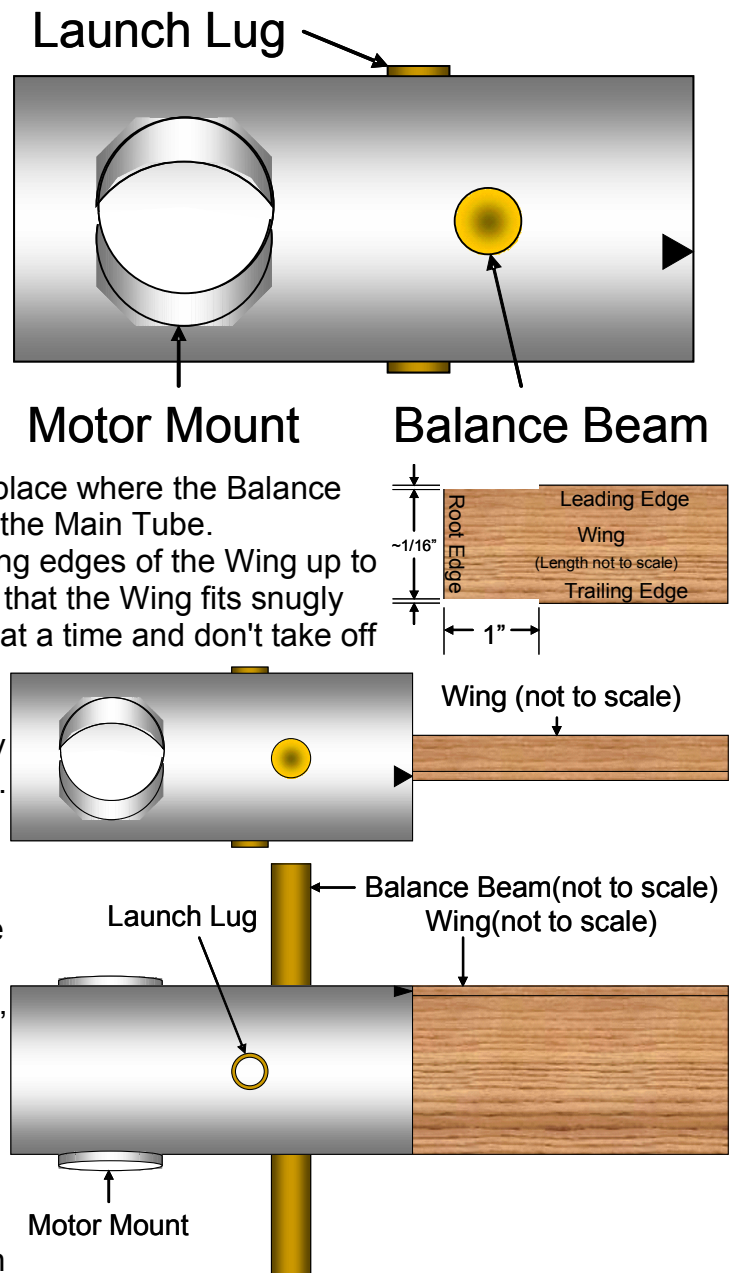

## 24 mm Helix - Page 3

Recommended Motors: D11-P, D12-0, D12-3, E9-P, E9-4, Apogee E6-P & E6-4. Reloadable motors are not recommended for this rocket.

Note: The casing of the motor may burn through just above the nozzle during some flights. The motor mount of the Helix may also be burned. This is unavoidable in some cases but it will always burn in the same place. It won't get any worse and it will not effect the performance of the Helix.

### Flight preparation:

Tightly wrap three layers of masking tape  $\frac{1}{2}$ " inch (1" for 3.75" long "E" motors) from the nozzle end of the motor to form a thrust ring. The motor should be centered in the Motor Mount.

Insert the motor into the Motor Mount with the nozzle tilting downward. If the motor is too loose, wrap a little masking tape around it until it fits tight enough not to fall out.

Install the igniter and attach the launch controller clips being careful to keep the wires out of the way of the, soon to be, rapidly rotating wing.

Launch the Helix from a 1.5 inch long,  $\frac{1}{4}$ " diameter launch rod. Do not use a longer or narrower rod because a long rod can whip around uncontrollably and cause the rocket to go in an unpredictable direction.

The launch pad should be sturdy and fixed firmly to the ground. A suitable launch pad can be constructed from the following materials:

4 - 2x4s, three, 18 inches long and one 36 inches long. The lengths need not be exact but should not be shorter than those specified.

1 - 3 inch long,  $\frac{1}{4}$ -20 carriage bolt and 3 nuts

6 - 3 inch long wood screws.

Drill a  $\frac{1}{4}$ " hole in the middle of one of the short 2x4s. Insert the carriage bolt into the hole and secure it tightly with a nut. Attach the long 2x4, perpendicular to the short one with two wood screws. Attach the two remaining short 2x4s to the opposite ends of the first short 2x4 with two wood screws each. Thread the remaining two nuts on the bolt and use them to adjust the height of the rocket.

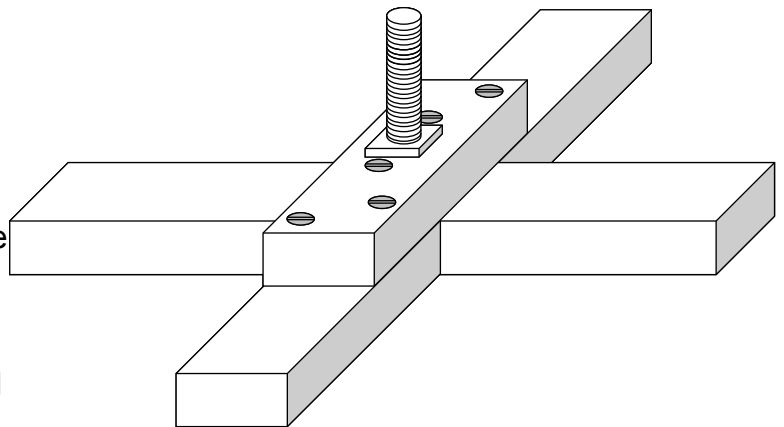

Limitation of Liability: Model rockets are not toys. Model rockets are functional rockets constructed of lightweight materials and launched using pre-manufactured, certified model rocket motors in accordance with the NAR Model Rocket Safety Code. Model rockets, if misused, can cause injury, property damage and even death. Art Applewhite Rockets certifies that it has exercised reasonable care in the design and manufacture of its products. Once sold, we cannot assume any liability for product storage, transportation or usage. Art Applewhite Rockets shall not be held responsible for any property damage or personal injury whatsoever arising from the handling, storage, use or misuse of our product. The buyer assumes all risks and liabilities there from and accepts and uses Art Applewhite Rockets products on these conditions.