

Art Applewhite Rockets

from deep in the heart of Texas



Hornet Monocopter

Recommended motors: A8-3, B4-2, B4-4, B6-0, B6-2, B6-4, C6-0, C6-3, C6-5

Parts:

Wing – 1/8" Basswood

Balance Beam – 8"x1/4" dowel

Support Dowels – 2.75"x3/16" dowels

Center, Center & Motor Supports – Basswood

Motor Mount Tube – 2" BT-20 tubing

Motor reinforcement – Fiberglass tape

Materials and Tools: Elmer's Glue-All, #11 X-Acto® knife, scissors, ruler, Drill & 1/4" bit.

Construction Tips:

- Read **all** the instructions before starting construction.
- Test fit all parts before gluing them.
- **Elmer's Glue-All** is the only recommended glue for this kit.
- There are at least 2 possible ways to assemble this kit. The order given is the most logical but the following order could be quicker because you can be doing other parts while the glue is drying on the motor mount. Start with Step 1, then 6, 2, 3, 7, 4, 10, 5, 6, 8, 9, 11. The choice is yours but whichever order you decide allow the glue time to dry before using the parts.
- If you have any questions please contact Art Applewhite at rocket877@aol.com

Construction:

1. Cut out the Center, Center Support and Motor Support. Be careful to follow the grain of the wood.
2. Glue the Center to the top of the Center Support. Once the glue has dried, run fillets of glue along all the joints.

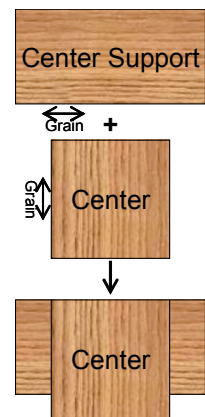
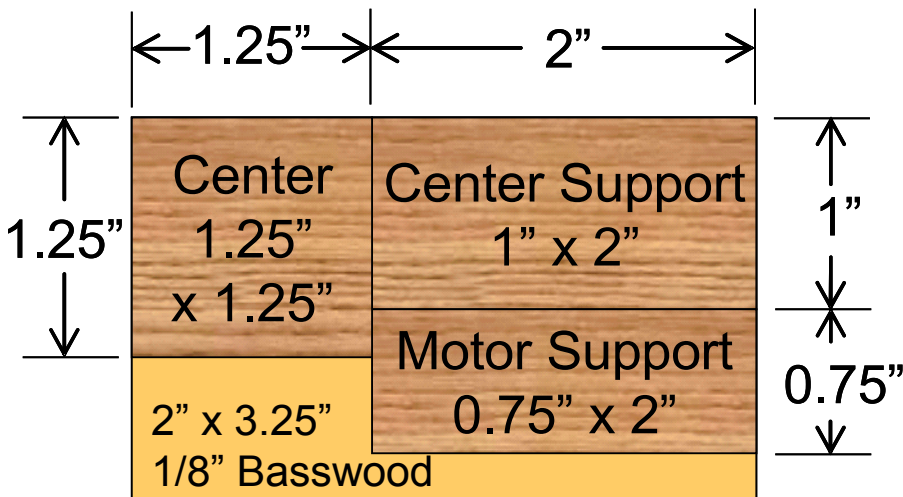
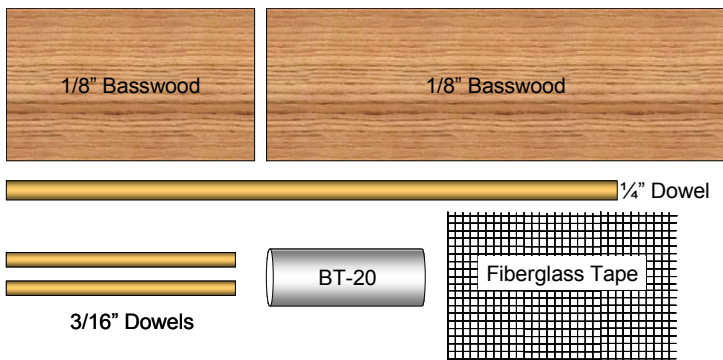

Hornet Monocopter - Page 2

3. Glue the Support Dowels to the sides of the Center and on top of the Center Support.
4. Glue the Balance Beam to the underside of the Center. The ends of the Balance Beam should be sticking out evenly on both sides. Once the glue has dried, run heavy fillets of glue along all the joints.
5. Glue the Wing to the Center and Support Dowels so that one side of the Wing is above one of the Support Dowels and the other side of the Wing is below the other Support Dowel. This will tilt the Wing to generate lift. Make sure the Wing is perpendicular to the Balance Beam.
6. Mark a straight line down the length of the BT-20 using a door frame as a guide. Glue the Motor Support to the BT-20 Motor Mount Tube. Make sure the tube is straight with the Motor Support.
7. Wrap the Fiberglass Tape around the Motor Mount Tube and over the Motor Support. Trim the Fiberglass Tape away from the edges with scissors. Coat the Fiberglass Tape with glue and work the glue into the weave.
8. Sand the ends of the Support Dowels if necessary so that they fit closely to the Motor Mount.
9. Glue the Motor Mount and Motor Support to the Center and Support Dowels so that one Support Dowel is above the Motor Support and the other Support Dowel is below it. The Motor Mount should be tilting in the opposite direction from the Wing. Once the glue is dry run a heavy fillet of glue along every joint.
10. Carefully drill a 1/4" hole for the launch rod in the middle of the Center 0.5" down from the Motor Support. The hole should be perpendicular to the Center and the Balance Beam.
11. Apply two light coats of clear (or any color you like) enamel to protect the wood and glue from moisture and dirt.

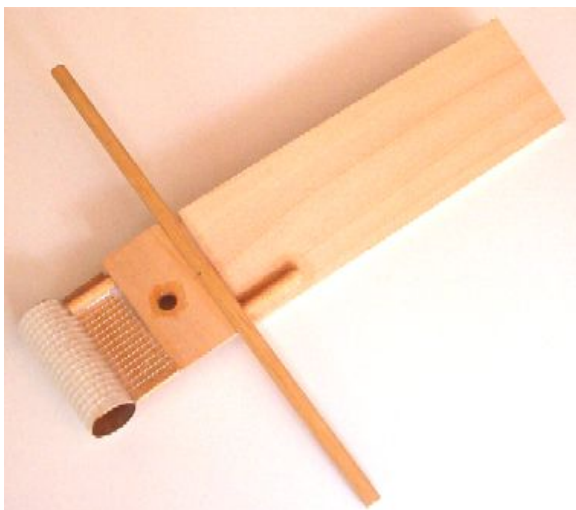
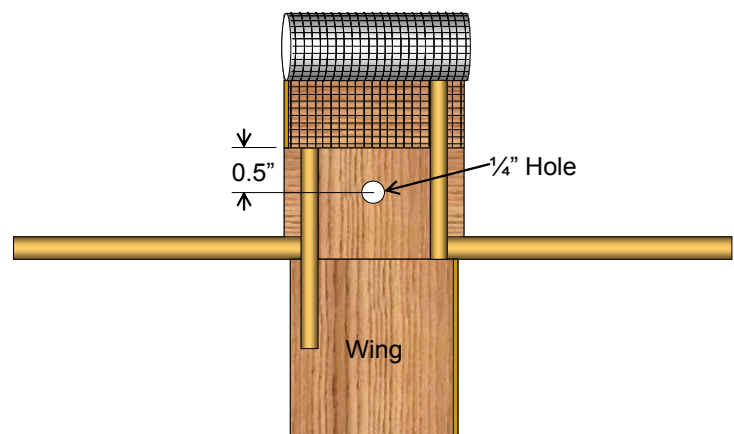
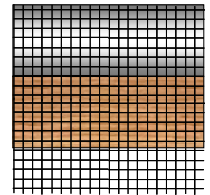
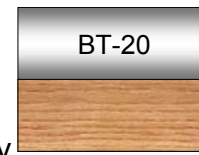
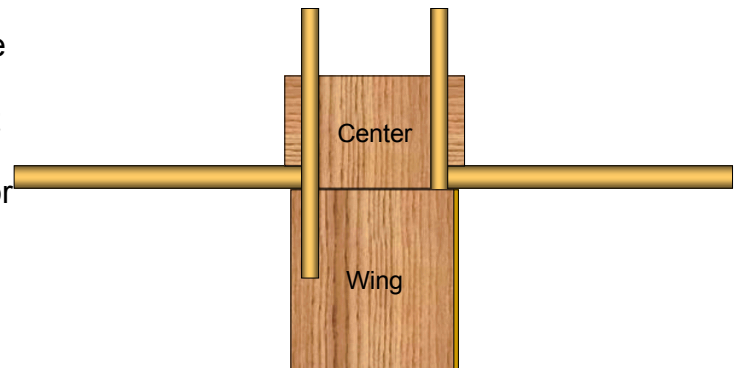
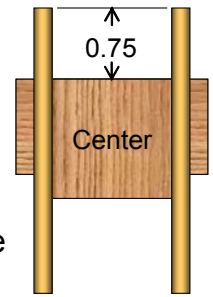

Hornet Monocopter - Page 3

Recommended Motors: A8-3, B4-2, B4-4, B6-0, B6-2, B6-4, C6-0, C6-3, C6-5

Note: This kit is designed to fly best on an Estes C6-3 motor.

Motors with ejection delays longer than 5 seconds are not recommended because the rocket may land before the ejection charge goes off and this can damage the rocket and possibly start a fire.

Flight preparation:

Wrap three layers of masking tape 3/8 inch from the nozzle end of the motor to form a thrust ring. Trim off any excess tape.

Insert the motor into the Motor Mount with the nozzle tilting downward and the Balance Beam above the Wing. If the motor is too loose, wrap a little masking tape around it until it fits tight enough not to fall out. The motor should be centered in the Motor Mount.



Install the igniter and attach the launch controller clips being careful to keep the wires out of the way of the, soon to be, rapidly rotating wing.

Launch the monocopter from a very short (no more than 1/2 inch long) 1/4" diameter launch rod. Do not use a longer or narrower rod because the rod can whip around a great deal and cause the rocket to go off in an unpredictable direction.

The launch pad should be sturdy and fixed firmly to the ground. A suitable launch pad can be constructed from the following materials:

4 - 2x4s, three, 18 inches long and one 36 inches long. The lengths need not be exact.

1 - 3 inch long, 1/4-20 carriage bolt and nut

6 - 3 inch long wood screws.

Drill a 1/4" hole in the middle of one of the short 2x4s. Insert the carriage bolt into the hole and secure it tightly with the nut. Attach the long 2x4, perpendicular to the underside of the short one with two wood screws. Attach the two remaining short 2x4s to the opposite ends of the first short 2x4 with two wood screws each.

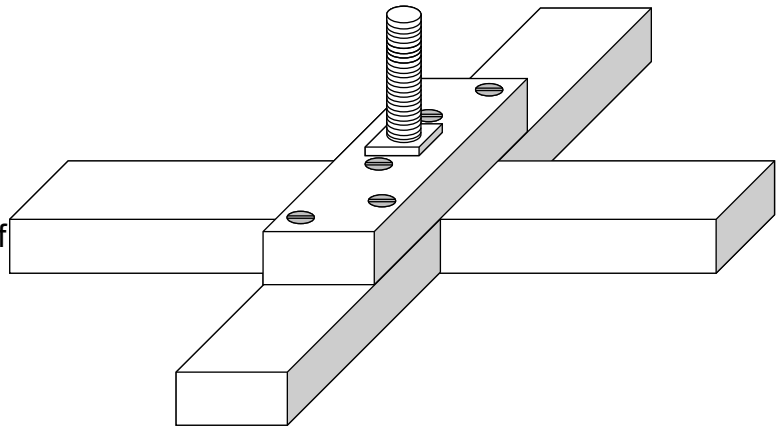

Limitation of Liability: Model rockets are not toys. Model rockets are functional rockets constructed of lightweight materials and launched using pre-manufactured, certified model rocket motors in accordance with the NAR Model Rocket Safety Code. Model rockets, if misused, can cause injury, property damage and even death. Art Applewhite Rockets certifies that it has exercised reasonable care in the design and manufacture of its products. Once sold, we cannot assume any liability for product storage, transportation or usage. Art Applewhite Rockets shall not be held responsible for any property damage or personal injury whatsoever arising from the handling, storage, use or misuse of our product. The buyer assumes all risks and liabilities there from and accepts and uses Art Applewhite Rockets products on these conditions.